

EC axial fan

sickle-shaped blades (S series)

with round full nozzle

ebm-papst Mulfingen GmbH & Co. KG

Bachmühle 2 · D-74673 Mulfingen

Phone +49 7938 81-0

Fax +49 7938 81-110

info1@de.ebmpapst.com

www.ebmpapst.com

Limited partnership · Headquarters Mulfingen

Amtsgericht (court of registration) Stuttgart · HRA 590344

General partner Elektrobau Mulfingen GmbH · Headquarters Mulfingen

Amtsgericht (court of registration) Stuttgart · HRB 590142

Nominal data

Type	W3G350-CA58-02	
Motor	M3G074-CF	
Phase		1~
Nominal voltage	VAC	230
Nominal voltage range	VAC	200 .. 277
Frequency	Hz	50/60
Method of obtaining data		fa
Speed (rpm)	min ⁻¹	1540
Power consumption	W	150
Current draw	A	1.2
Min. ambient temperature	°C	-25
Max. ambient temperature	°C	60

ml = Max. load · me = Max. efficiency · fa = Free air · cs = Customer specification · ce = Customer equipment
Subject to change

Data according to Commission Regulation (EU) 327/2011

		Actual	Req. 2015
01 Overall efficiency η_{es}	%	41.6	28.6
02 Measurement category		A	
03 Efficiency category		Static	
04 Efficiency grade N		53	40
05 Variable speed drive		Yes	

Data obtained at optimum efficiency level.

The ErP data is determined using a motor-impeller combination in a standardized measurement setup.

09 Power consumption P_{ed}	kW	0.16
09 Air flow q_v	m ³ /h	2195
09 Pressure increase p_{fs}	Pa	100
10 Speed (rpm) n	min ⁻¹	1450
11 Specific ratio*		1.00

* Specific ratio = $1 + p_{fs} / 100\,000\text{ Pa}$

LU-71540



EC axial fan

sickle-shaped blades (S series)

with round full nozzle

Technical description

Weight	2.9 kg
Size	350 mm
Motor size	74
Electronics housing material	Die-cast aluminum
Impeller material	Sheet steel, painted black
Number of blades	5
Airflow direction	A
Direction of rotation	Clockwise, viewed toward rotor
Degree of protection	IP44; installation- and position-dependent as per EN 60034-5
Insulation class	"B"
Moisture (F) / Environmental (H) protection class	F3-1; H1+
Max. permitted ambient temp. for motor (transport/storage)	+ 80 °C
Min. permitted ambient temp. for motor (transport/storage)	- 40 °C
Installation position	Shaft horizontal or rotor on bottom; rotor on top on request
Mode	S1
Motor bearing	Ball bearing
Technical features	<ul style="list-style-type: none"> - Output 10 VDC, max. 1.1 mA - Tach output - Motor current limitation - Soft start - Control input 0-10 VDC / PWM - Thermal overload protection for electronics/motor
EMC immunity to interference	According to EN 61000-6-2 (industrial environment)
EMC circuit feedback	According to EN 61000-3-2/3
EMC interference emission	According to EN 61000-6-3 (household environment)
Touch current according to IEC 60990 (measuring circuit Fig. 4, TN system)	<= 3.5 mA
Motor protection	Thermal overload protector (TOP) internally connected
With cable	Variable
Protection class	I (with customer connection of protective earth)
Conformity with standards	CE
Approval	CSA C22.2 No. 77 + CAN/CSA-E60730-1; UL 1004-3 + 60730-1



EC axial fan

sickle-shaped blades (S series)
with round full nozzle

Product drawing

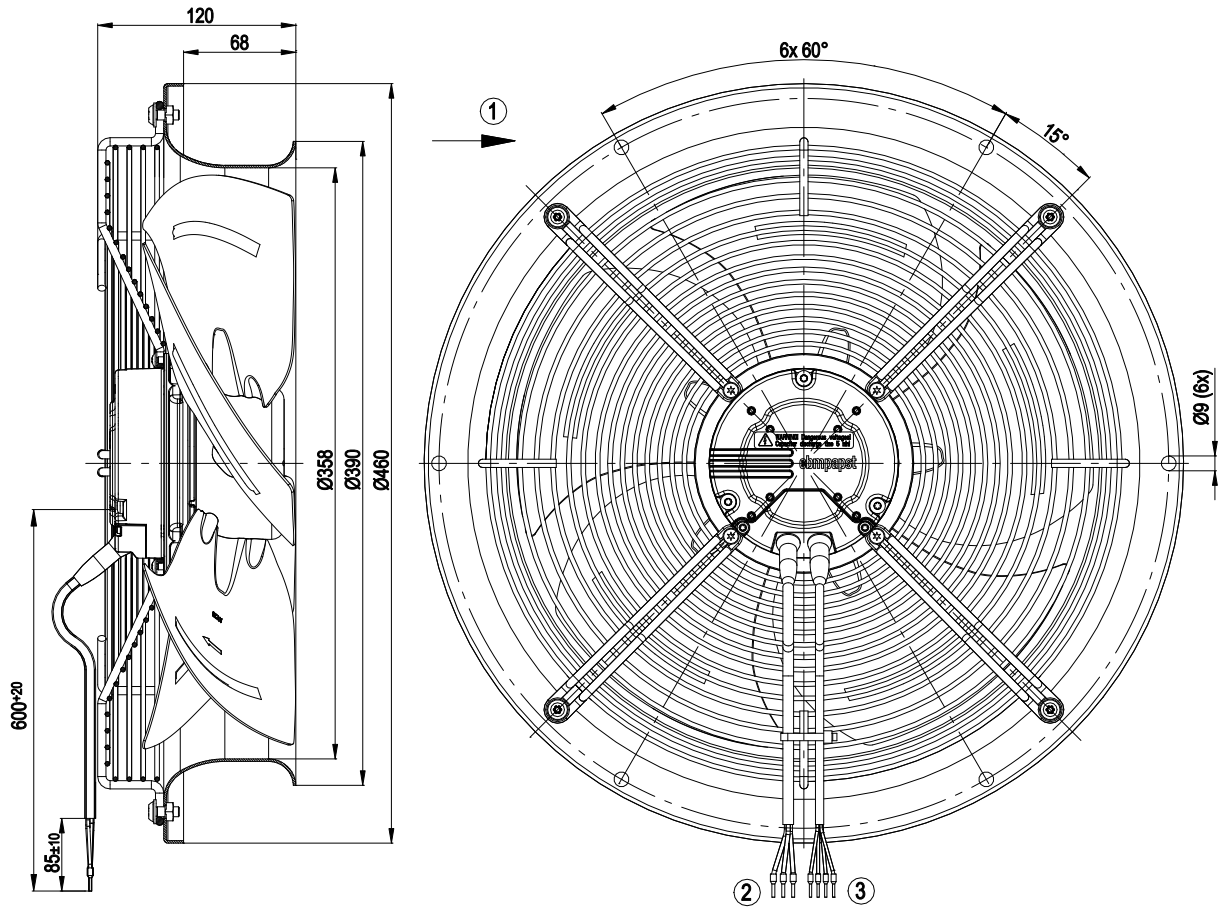

1	Direction of air flow "A"
2	Cable AWG18, 3x crimped splices
3	Cable AWG22, 4x crimped splices



EC axial fan

sickle-shaped blades (S series)
with round full nozzle

Connection diagram

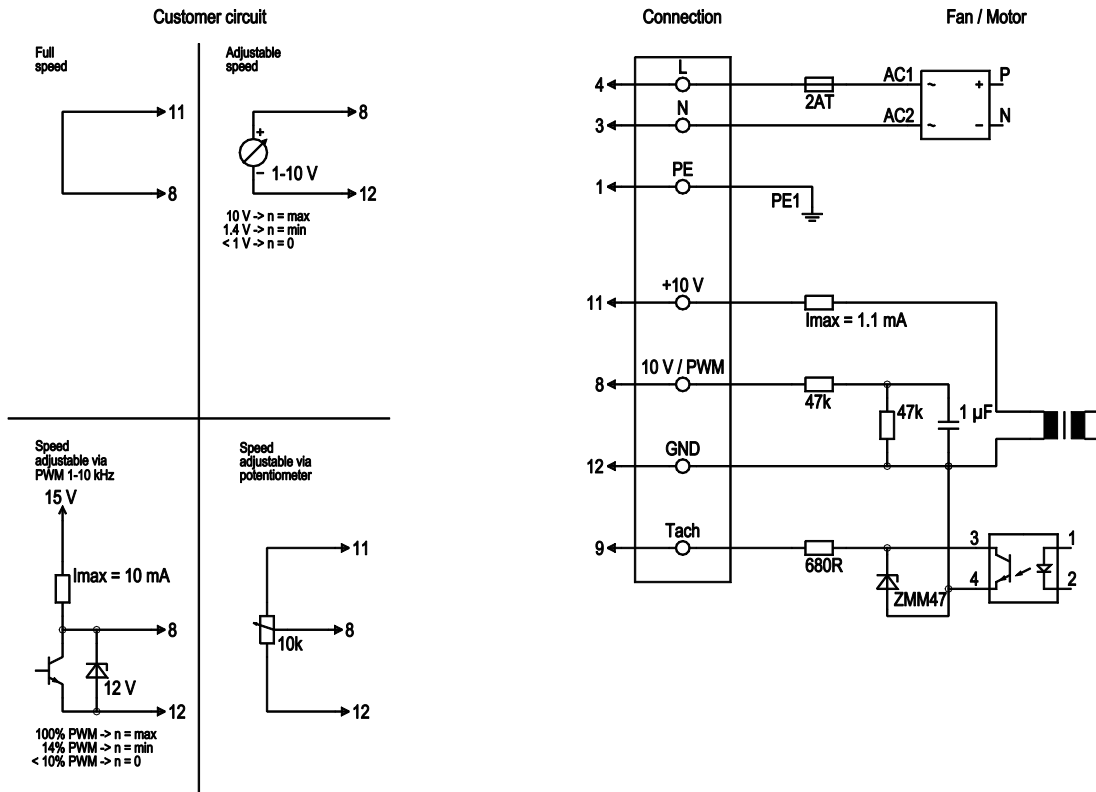

No.	Conn.	Designation	Color	Function/assignment
	4	L	black	Power supply 230 VAC, 50-60 Hz, see nameplate for voltage range
	3	N	blue	Neutral conductor
	1	PE	green/yellow	Protective earth
	8	0-10 V PWM	yellow	Control input 0-10 V or PWM, electrically isolated
	9	Tach	white	Tach output: open collector, 1 pulse per revolution, electrically isolated
	11	10V / max 1.1 mA	red	Voltage output 10 V/max. 1.1 mA, electrically isolated
	12	GND	blue	GND connection for control interface



EC axial fan

sickle-shaped blades (S series)
with round full nozzle

Curves: Air performance 50 Hz

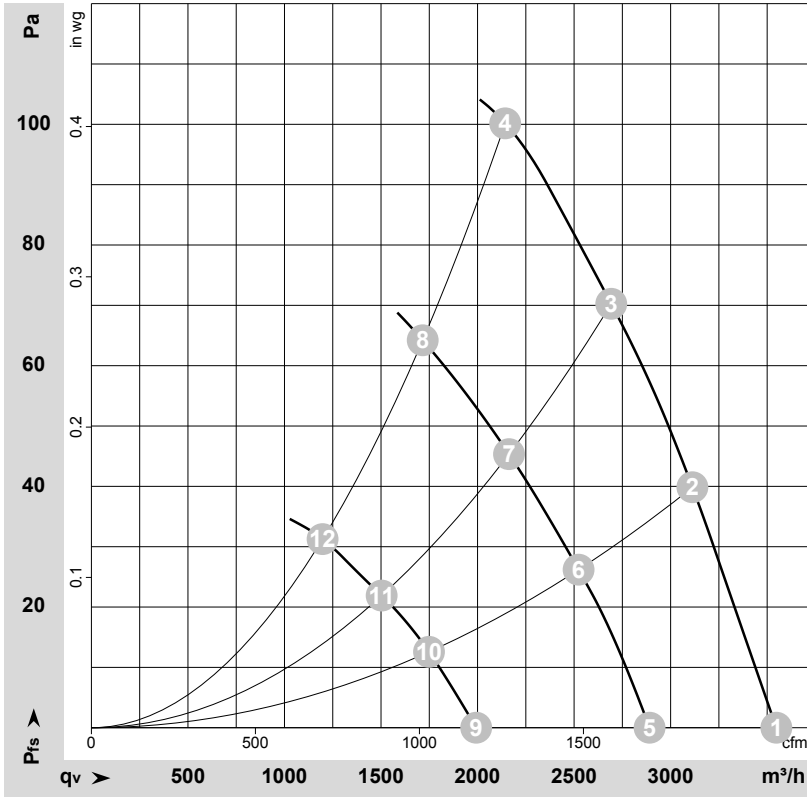

$\rho = 1.15 \text{ kg/m}^3 \pm 2 \%$

Measurement: LU-71540-1
Measurement: LU-71541-1
Measurement: LU-71542-1

Air performance measured according to ISO 5801 installation category A. For detailed information on the measurement setup, contact ebm-papst. Intake sound level: Sound power level according to ISO 13347 / sound pressure level measured at 1 m distance from fan axis. The values given are valid under the specified measuring conditions and may vary due to conditions of installation. For deviations from the standard configuration, the parameters have to be checked on the installed unit.

Measured values

	U	f	n	P _{ed}	I	q _v	P _{fs}	q _v	P _{fs}
	V	Hz	min ⁻¹	W	A	m ³ /h	Pa	cfm	in. wg
1	230	50	1540	150	1.20	3550	0	2090	0.00
2	230	50	1510	166	1.25	3115	40	1830	0.16
3	230	50	1480	167	1.25	2690	70	1585	0.28
4	230	50	1440	167	1.23	2145	100	1260	0.40
5	230	50	1255	87	0.66	2890	0	1700	0.00
6	230	50	1220	90	0.69	2525	26	1485	0.10
7	230	50	1190	89	0.69	2165	46	1275	0.18
8	230	50	1150	91	0.69	1715	64	1010	0.26
9	230	50	870	33	0.27	1995	0	1175	0.00
10	230	50	845	35	0.28	1750	13	1030	0.05
11	230	50	830	34	0.28	1505	22	885	0.09
12	230	50	810	34	0.27	1195	32	705	0.13

U = Voltage · f = Frequency · n = Speed (rpm) · P_{ed} = Power consumption · I = Current draw · q_v = Air flow · P_{fs} = Pressure increase

