

Operation and Maintenance Instructions for ec aura 115V



Part No: ec aura

Manufacturer: ebm-papst UK Ltd

Stationary class 1 motor operated appliance
with a fixed supply cord

Copyright© ebm-papst UK Ltd 2012
This document, including any concepts or techniques used,
is the intellectual property of ebm-papst UK Ltd.

Operation and Maintenance Instructions

for ec aura

INDEX

1	DATASHEET	3
2	SUMMARY	4
3	SUB ASSEMBLY	5
4	CERTIFICATE OF CONFORMITY	6



ec aura



Stand alone fan offering an energy efficient low noise solution to temporary cooling requirements.

- Robust Polyethylene moulding
- Extrusion coated polypropylene impellor
- Heavy duty powder-coated wheeled frame for effortless positioning
- Infinitely variable speed control
- Available in 230VAC & 110VAC 50/60Hz versions
- 180° adjustable tilt angle
- Maintenance-free IP54 Motor
- Supplied with standard UK 3-pin 230VAC or 110VAC plug

Part Number	Supply Voltage	Frequency	Maximum airflow	Max. Current Draw	Max. power input	Sound Pressure @ 3M	Mass	Max. Ambient Temperature	Air Velocity @ 5M	Air Velocity @ 10M	Air Velocity @ 15M	Air Velocity @ 20M
	VAC	Hz	m ³ /h	Amps	kW	dB(A)		°C	m ³ /s	m ³ /s	m ³ /s	m ³ /s
Cool500ec-230	230	50/60	7250	2.2	0.36	67	27	+55	2.3	1.3	1.1	1.0
Cool500ec-115	115	50/60	7250	3.3	0.37	67	27	+55	2.3	1.3	1.1	1.0

Dimensions

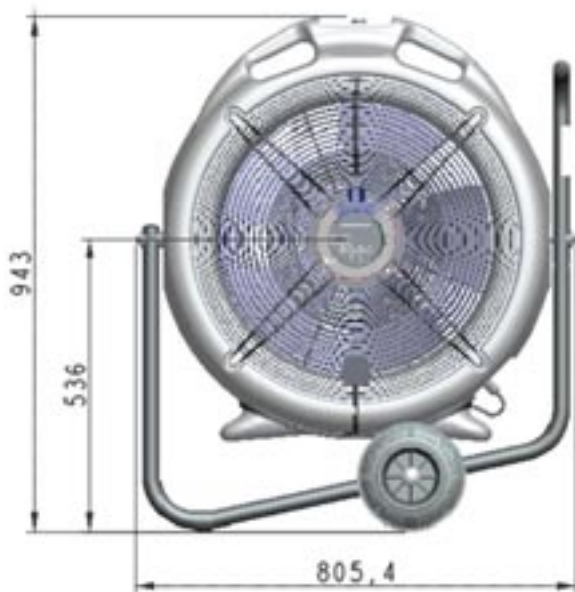

Standards:

The ec aura range is RoHS compliant and CE marked.



Operating Instructions:

- Do not operate appliance in explosive atmosphere
- Do not stick fingers or objects through guards
- Keep guards clear from obstructions
- If the supply cord is damaged, it must be replaced by the manufacturer, its service agent or similarly qualified persons in order to avoid a hazard
- Do not leave under 14's unsupervised when the appliance is in operation

Maintenance Instructions:

- This appliance contains no user serviceable parts
- Clean with damp cloth only, do not jet / power wash

Specification:

Class: Stationary class 1 motor operated appliance with a fixed supply cord

Manufacturer: ebm-papst UK Ltd

Part no: ec aura

Voltage: 115V AC 50Hz

Current: 5A

Safety:

Mains plug is a disconnection device

Earth Bond Resistance: Nominally 0.16 Ohms

End of Life:

This product has been designed to consider re-use and end-of-life disposal. The parts likely to wear during use, the tilt mechanism, electric motor/fan and speed control unit are designed for easy repair or replacement. The manufacturer should undertake the repair of the components, but a suitably qualified and competent person can undertake replacement of the components, enabling the life of the product to be extended.

If the product has come to the end of its life and it is not practical to repair then the unit can be easily disassembled for the components to be recycled. The product has been designed to meet the requirements of the RoHS directive and most of the materials can be recycled.

See next page for diagram to assist in dismantling the unit

Control panel sub assembly

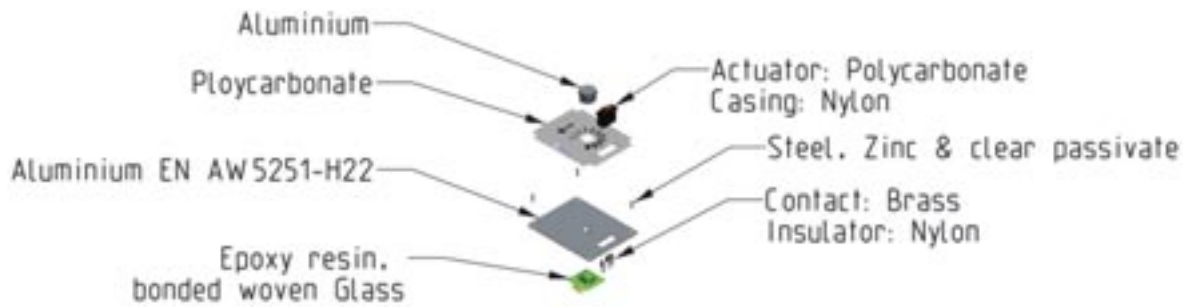

Housing sub assembly

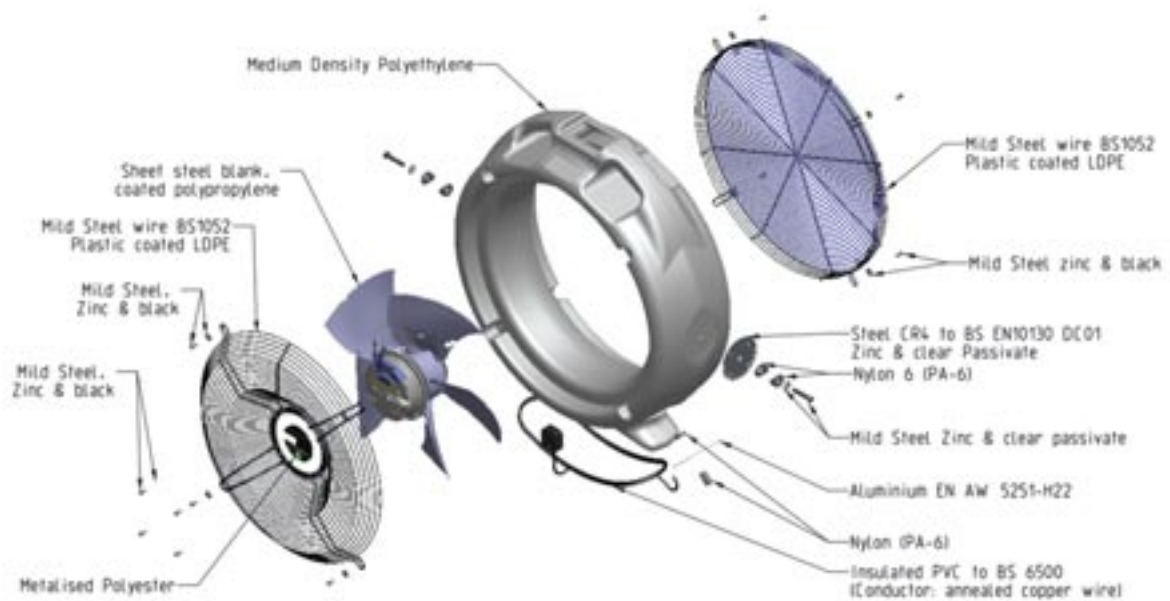

Trolley sub assembly

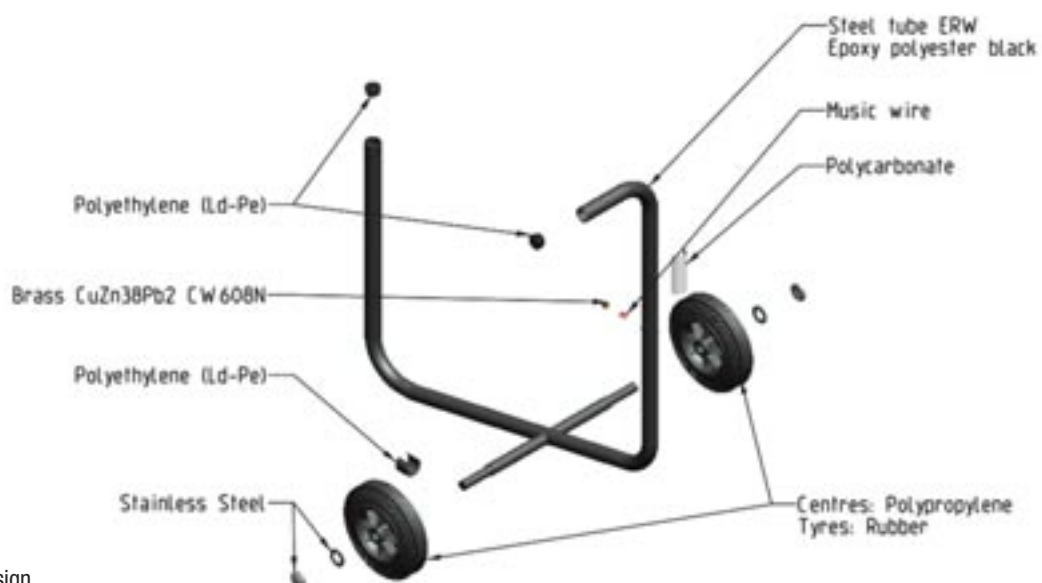

Registered design

Operation and Maintenance Instructions for ec aura 115V